

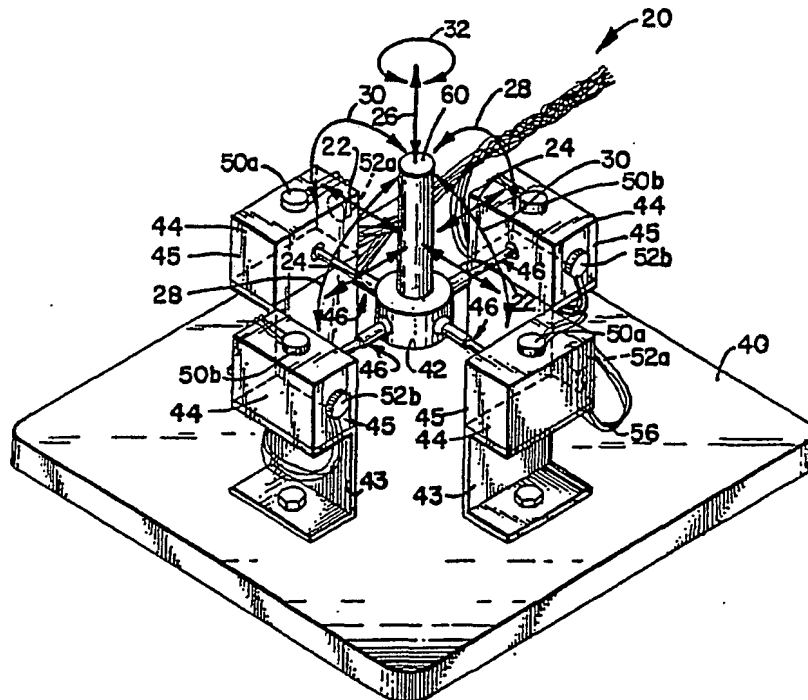

INTERNATIONAL APPLICATION PUBLISHED UNDER THE PATENT COOPERATION TREATY (PCT)

<p>(51) International Patent Classification<sup>4</sup> : <b>G06F 3/033</b></p>	<p><b>A1</b></p>	<p>(11) International Publication Number: <b>WO 88/ 05942</b> (43) International Publication Date: 11 August 1988 (11.08.88)</p>
<p>(21) International Application Number: PCT/US88/00291 (22) International Filing Date: 29 January 1988 (29.01.88) (31) Priority Application Numbers: 010,851 144,266 (32) Priority Dates: 4 February 1987 (04.02.87) 15 January 1988 (15.01.88) (33) Priority Country: US (71) Applicant: MAYO FOUNDATION FOR MEDICAL EDUCATION AND RESEARCH[US/US]; 200 First Street S.W., Rochester, MN 55905 (US). (72) Inventors: ROBB, Richard, A. ; 1121 21st Street N.E., Rochester, MN 55901 (US). ERICKSON, Bradley, J. ; 625 19th Street N.W., Rochester, MN 55901 (US).</p>		<p>(74) Agent: SCHUMANN, Michael, D.; Merchant, Gould, Smith, Edell, Welter &amp; Schmidt, 1600 Midwest Plaza Building, Minneapolis, MN 55402 (US). (81) Designated States: AT, AT (European patent), AU, BB, BE (European patent), BG, BJ (OAPI patent), BR, CF (OAPI patent), CG (OAPI patent), CH, CH (Eu- ropean patent), CM (OAPI patent), DE, DE (Euro- pean patent), DK, FI, FR (European patent), GA (OAPI patent), GB, GB (European patent), HU, IT (European patent), JP, KP, KR, LK, LU, LU (Euro- pean patent), MC, MG, ML (OAPI patent), MR (OA- PI patent), MW, NL, NL (European patent), NO, RO, SD, SE, SE (European patent), SN (OAPI pa- tent), SU, TD (OAPI patent), TG (OAPI patent).  Published <i>With international search report.</i></p>

(54) Title: JOYSTICK APPARATUS HAVING SIX DEGREES FREEDOM OF MOTION



(57) Abstract

A joystick apparatus (20) having six degrees of motion, namely, translational motion along X, Y and Z axes and rotational motion about the X, Y and Z axes.

***FOR THE PURPOSES OF INFORMATION ONLY***

Codes used to identify States party to the PCT on the front pages of pamphlets publishing international applications under the PCT.

AT	Austria	FR	France	ML	Mali
AU	Australia	GA	Gabon	MR	Mauritania
BB	Barbados	GB	United Kingdom	MW	Malawi
BE	Belgium	HU	Hungary	NL	Netherlands
BG	Bulgaria	IT	Italy	NO	Norway
BJ	Benin	JP	Japan	RO	Romania
BR	Brazil	KP	Democratic People's Republic of Korea	SD	Sudan
CF	Central African Republic	KR	Republic of Korea	SE	Sweden
CG	Congo	LI	Liechtenstein	SN	Senegal
CH	Switzerland	LK	Sri Lanka	SU	Soviet Union
CM	Cameroon	LU	Luxembourg	TD	Chad
DE	Germany, Federal Republic of	MC	Monaco	TG	Togo
DK	Denmark	MG	Madagascar	US	United States of America
FI	Finland				

-1-  
JOYSTICK APPARATUS HAVING SIX DEGREES FREEDOM OF MOTION

This application is a continuation-in-part of serial number 010,851 filed February 4, 1987.

5

Background of the Invention

The present invention relates to a user input device, hereafter referred to as a joystick apparatus, capable of being moved in all directions so as to have six  
10 degrees freedom of motion, namely, translational motion along x, y, and z axes, and rotational motion about x, y, and z axes. More particularly, the present invention provides a joystick apparatus with significant advantages in manipulating three-dimensional computer generated images  
15 on display media as well as manipulation of objects in three-dimensional space.

Joysticks are typically electrically interconnected to computer control systems for permitting manual input of positioning or other information.  
20 Joysticks have long been used to control and manipulate objects and images on a display medium. For example, in electronic arcade games, joysticks are typically used to control two-dimensional movement of images on a display medium. Such a joystick may be defined as a control device  
25 comprising a handle with freedom of motion in all directions of a plane; i.e., translational movement along x and y axes of the plane. Joysticks have also been used to control three-dimensional movement of objects and movement of images on display media. Such joysticks typically  
30 comprise a vertically mounted stick or column which can be moved in all directions of a plane and rotated about an axis perpendicular to the plane. U.S. Patent Nos. 4,046,005; 4,217,569; and 4,468,688 are examples of such joysticks. When moved backward, forward, or sideways, x  
35 and y coordinate values are typically varied, with the z coordinate value being varied whenever the joystick is rotated clockwise or counterclockwise. Typically, the x, y, and z coordinate values are stored in corresponding x, y

-2-

and z registers which are periodically scanned by a host computer system, since joysticks normally do not generate interrupts when they are activated. However, some joysticks do generate an interrupt which is transmitted to the host computer system whenever the joystick is activated by moving the joystick handle. The values of the x, y, and z input registers are used by the host computer system to control orientation and movement of the three-dimensional images on the display medium. Numerous efforts have been made at improving joystick performance and interaction with a user. The following patent references disclose some of these efforts:

	<u>PATENT NO.</u>	<u>PATENTEE</u>	<u>ISSUE DATE</u>
15	4,046,005	Goroski	Sept. 6, 1977
	4,161,726	Burson et al.	July 17, 1979
	4,217,569	Nejedly et al.	Aug. 12, 1980
	4,382,166	Kim	May 3, 1983
20	4,468,688	Gabriel et al.	Aug. 28, 1984
	4,536,746	Gobeli	Aug. 20, 1985

The above patent references disclose joysticks having three degrees freedom of motion, namely, translational motion relative to the x and y axes, and rotational movement about the z axis. Although some of the references may provide for three-dimensional control of images on a display medium, they do not provide a joystick apparatus having six degrees freedom of motion corresponding to the six degrees freedom of motion possible in three-dimensional space. Some joysticks utilize force sensing as opposed to movement sensing. However, these devices often do not have the desired accuracy and intuitiveness. Although, arguably there is some minute amount of movement present in force sensing, it is insufficient to provide useful intuitive feedback to the user.

-3-

The present invention solves these problems and others associated with existing input devices, providing for user control and manipulation of objects in three-dimensional space and three-dimensional computer generated images in a very intuitive and interactive way by manipulation of the joystick apparatus in a manner which corresponds to the manipulation of a three-dimensional object in three dimensional space.

Summary of the Invention

10 The present invention relates to a joystick apparatus having a central body means supported for translational and rotational movement in any direction within a limited three-dimensional space. The joystick apparatus includes sensor means spaced apart from the  
15 central body means for sensing movement of the central body means.

In one embodiment, the present invention also relates to a computer graphics input device used for controlling movement of an image on a computer graphics display terminal, the input device including body means supported for translational and rotational movement in any direction within a limited three-dimensional space and transducer means for sensing movement of the body means and converting the sensed movement into output signals  
20 representative of the sensed movement.

In one embodiment, the sensor means are slidably mounted for linear movement generally away and toward the central body.

In yet other embodiments, the central body is  
30 connected to stationary sensor means by telescoping means.

In one embodiment, the present invention relates to a joystick apparatus having a central body portion with six degrees freedom of motion, namely, translational motion along x, y, and z axes and rotational motion about x, y,  
35 and z axes. The joystick apparatus includes a support

-4-

base. The joystick apparatus further includes a central  
body portion interconnected to at least three, two-  
dimensional joystick apparatus each having a base portion  
and control handle means interconnected to the base portion  
5 so as to have two degrees of motion. A two-dimensional  
joystick apparatus includes linear sensor means, typically  
there being two such linear sensors present, for sensing  
movement of the control handle means and for providing  
corresponding output signals. The control handle means is  
10 interconnected to the central body portion by universal  
joint means for universal movement and including adjustable  
length means for providing the handle means with adjustable  
length so as to enable adjustable displacement between the  
central body portion and the base portion of the two-  
15 dimensional joystick apparatus, whereby the central body  
portion is provided with six degrees of motion, namely,  
translational motion along the x, y, and z axes and  
rotational movement about the x, y, and z axes. The  
universal joint means is disposed about the central body  
20 portion at predetermined locations. A main control handle  
means extends from the central body portion for  
facilitating user manipulation of the central body portion.

It will be appreciated that the joystick  
apparatus might include force transducer sensors as opposed  
25 to motion transducer sensors. Movement from one location  
to another in three-dimensional space has both a magnitude  
component and a direction component. The direction  
component of any such movement in three-dimensional space  
can be defined in terms of its x, y, and z components;  
30 i.e., movement relative to x, y, and z axes which are  
perpendicular to one another and which define a coordinate  
system for the three-dimensional space. Movement can  
involve translational and/or rotational movement relative  
to these axes; herein referred to as translational movement  
35 along the x, y, and z axes and rotational movement about

-5-

the x, y, and z axes. Accordingly, in three-dimensional space, there are six possible degrees freedom of motion, namely, translational motion along the x, y, and z axes, and rotational motion about the x, y and z axes. Movement  
5 in three-dimensional space, other than translational movement along and rotational about only one axis, involves simultaneous movement along a plurality of the x, y, and z axes. The present invention provides a joystick apparatus which functions as a user input device capable of  
10 indicating both movement and the magnitude of that movement. Moreover, the user input device is capable of movement simultaneously along a plurality of the axes x, y, and z.

The present invention provides a joystick  
15 apparatus having a control handle which can be moved in all directions so as to have six degrees freedom of motion corresponding to the six degrees freedom of motion of a three-dimensional object in three-dimensional space. Accordingly, the joystick apparatus of the present  
20 invention provides for user control and manipulation of objects and computer generated images in a very intuitive and interactive fashion. The joystick apparatus of the present invention can be readily interconnected to a computer system such that movement of the joystick  
25 apparatus directly corresponds to movement of the object and/or image being displayed on a display medium. That is, rotating the joystick will cause a similar rotation of the object or image and translational, also referred to as linear, movement of the joystick will cause a similar  
30 translational movement of the object or image. A feed-back loop may be present to provide a lag or lead time between movement of the joystick and the image or object. For example, in manipulating a three-dimensional image on a display medium, any desired view, orientation can be  
35 achieved by moving the control handle of the joystick as if

-6-

it were the image, since movement of the joystick directly corresponds to movement of the image. It will be appreciated that this facilitates and enhances user manipulation and orientation of objects and images.

5           One embodiment of the present invention preferably utilizes a plurality of one-dimensional sensors, also referred to as linear sensors, each capable of sensing one-dimensional translational movement along a straight line such as along one of the x, y, and z axes.

10           In some embodiments, rotational sensors are also used.

In yet other embodiments, in addition to sensing movement (direction and magnitude), the sensors can also be used to detect velocity and acceleration.

15           In the preferred embodiment, a plurality of joystick-type sensors each including sensors so as to be capable of sensing two-dimensional movement in a plane are utilized.

20           The sensors used by the joystick-type sensors might include a wide variety of sensor types such as force or motion transducers which will convert movement of the joystick apparatus central body into suitable electrical signals.

25           Linear motion sensors might include variable resistor sensors, optical sensors, switches, encoders, various digital sensors, etc.

30           In the preferred embodiment, the joystick apparatus is used with variable resistors or voltage output devices which will contain the information for the six degrees of movement. However, it will be appreciated that other types of one-dimensional sensors might be used, such as a digital sensor. A computer software interface will utilize the inputs from these variable resistors to control movement of the three-dimensional graphic images. It will  
35           be appreciated that the software interface required to



perform this task will be designed based on well known algorithms for controlling motion of three-dimensional images. Therefore, once given the benefit of the applicants' disclosure, the software interface algorithms  
5 are readily known to those of ordinary skill in the art.

In still other embodiments of the present invention, the input signals from the sensors will be used for controlling various types of input parameters such as calculating lag and/or lead times as well as varying the  
10 rate and/or acceleration of movement.

Although the preferred embodiment uses four (4) spaced apart, two-dimensional joystick apparatus, alternate embodiments might utilize three or more (e.g. five, six, etc.) two-dimensional joystick apparatus. The provision of  
15 additional two-dimensional joystick apparatus will provide redundancy of signals which allows for averaging of the joystick output signals. As few as two, three-axis, joystick apparatus might also be used. The multiple joystick configuration might provide increased support for  
20 the control handle of the joystick apparatus.

In one embodiment of the present invention, the control handle might be resiliently biased so as to return to a neutral position when released by the user. In other embodiments, the control handle will remain where it is  
25 placed.

The control handle of the present invention might take on any number of configurations such as an elongated member or a sphere. Indeed, a central body portion of the joystick might serve as the control handle.

In one embodiment of the present invention, a plurality of sensors radially disposed from a central body, are interconnected to the central body so as to detect translational and rotational movement of the central body in three-dimensional space and provide output signals  
30 representative of such movement.  
35

-8-

These and various other advantages and features of novelty which characterize the present invention are pointed out with particularity in the claims annexed hereto and forming a part hereof. However, for a better understanding of the invention, its advantages and objects attained by its use, reference should be had to the drawings which form a further part hereof and to the accompanying descriptive matter and in which there is illustrated and described an embodiment of the invention.

10

Brief Description of the Drawings

In the drawings, in which like reference numerals indicate corresponding parts throughout the several views;

Figure 1 is a perspective view of an embodiment of a joystick apparatus in accordance with the principles of the present invention;

Figure 2 is a view similar to Figure 1 illustrating an embodiment of the present invention where only two three-dimensional joystick apparatus are present;

Figure 3 is a view of the embodiment shown in Figure 1 enclosed by a housing;

Figure 4 is a block diagram view of a computer graphics system wherein a joystick apparatus of the present invention might be utilized;

Figure 5 is a schematic top plan view of an embodiment of a joystick apparatus in accordance with the principles of the present invention;

Figure 6 is a side elevational view as seen generally along line 6-6 in Figure 5 of the embodiment illustrated in Figure 1;

Figure 7 is an electrical diagram of a conventional two-dimensional joystick;

Figure 8 is a mechanical diagram of a conventional two-dimensional joystick;

-9-

Figure 9 is a view similar to Figure 1 of yet another embodiment of the present invention; and

Figure 10 is a cross-sectional diagrammatic view of the embodiment shown in Figure 9.

5

Detailed Description of a Preferred Embodiment

Referring now to Figure 1, 3 and 5-6, there is illustrated an embodiment of a user input device, hereafter referred to as a joystick apparatus, generally referred to by the reference numeral 20, in accordance with the principles of the present invention. The joystick apparatus 20 of the present invention provides for translational and rotational movement in any direction; i.e., six simultaneous degrees of freedom (motion) or, namely, simultaneous translational movement along x, y and z axes as generally illustrated by arrows 22, 24, 26, respectively, and simultaneous rotational movement about the x, y, and z axes as generally illustrated by the arrows 28, 30, 32, respectively. In the embodiment shown, the joystick apparatus has a range of rotation of roughly  $\pm 45^\circ$  about the x, y and z axes, and has a range of translational motion of roughly  $\pm 1.5$  inches or  $\pm 3.8$  centimeters. For purposes of this description, movement is discussed in terms of x, y, and z axes perpendicular to one another which define a coordinate grid in three-dimensional space. As illustrated in Figure 1, the joystick apparatus is mounted on a support base 40. A central body portion 42 is interconnected to and supported by four conventional, two-dimensional joysticks 44 (also referred to as two-axis joysticks) each of which include linear sensors for sensing two-dimensional movement in a plane. Although, in alternate embodiments, as illustrated in Figure 2, wherein corresponding reference numerals are primed, the present invention might be implemented with only two joysticks 44'. In this embodiment, the joysticks 44' (also referred to as

-10-

three- axis joysticks) are capable of sensing rotational motion about a z-axis in addition to planar motion in the x-y plane. Typically, a twist knob is mounted on the handle of these joysticks. In yet other embodiments, three  
5 or any number of joysticks might be used.

The joysticks 44 include a base portion 45 and extensible (telescoping) handle members 46 which interconnect the base portion 45 of the joystick 44 to the central body portion 42. The handle members 46 are  
10 suitable interconnected to the base portions 45 of the joysticks 44 by a slider and ball joint arrangement 33 as illustrated in Figure 8 so as to provide for two degrees freedom of motion in a plane as is common in joysticks. In the embodiment shown, the joysticks 44 are fixedly  
15 supported above a surface of the support base by suitable support structure 43. The handle members 46 shown, include telescoping piston and cylinder portions 46a,b also referred to as telescoping tubing portions, so as to enable sliding motion therebetween. The cylinder portions 46b are  
20 interconnected to the central body portion 42 by a universal joint such as a ball joint 48. It will be appreciated that any number of u-joint arrangements might be used. For example, the cylinder portions 46b interconnected to the central body portion 42 by a  
25 flexible, resilient member. Also, the cylinder portions 46b might be disposed in an opening in the central body portion 42 having a greater diameter than the cylindrical portions 46b so as to allow movement of the central body portion 42. In the embodiment shown, the inner piece of  
30 each cylinder or tubing 46b has a ball mounted in a socket of the central body portion 42, such that the ball joints 48 are disposed about the central body portion in a common plane at ninety degree intervals. It will be appreciated that in alternate embodiments, the joysticks might not lie  
35 in the same plane. Indeed, they need not necessarily be

-11-

mutually orthogonal but must be non-coaxial or not all lined up, along a common axis. In a preferred arrangement, the radius of the central body portion 42 is one-half the distance between a center of the central body portion 42 and the pivotal point of attachment of the handle members 46 to the base portions 45 of the joysticks 44.

As shown in Figure 3, the joystick apparatus 20 will preferably be enclosed by a housing 47 having an opening for projection therethrough of a control handle portion 60 interconnected to the central body portion 42, the opening allowing movement of the control handle portion 60 along the x, y, and z axes. In the embodiment shown, the opening is enclosed by flexible rubber-like layer 49 so as to allow movement of the handle 60 but enclose the inside of the joystick apparatus. The top of the housing 47 in this embodiment might serve as a place for resting the user's hand.

The movement of the central body portion 42 is sensed by variable resistors 50, 52 associated with the four two-dimensional joysticks 44. It will be appreciated that other sensors might be used in keeping with the principles of the present invention. For example, various types of digital sensors might be used. Illustrated in Figure 7 is an electrical diagram 51 of a conventional two-dimensional joystick as might be used in the present invention, and illustrated in Figure 8 is a mechanical diagram of a conventional two-dimensional joystick 53 such as might be used in the present invention. In the embodiment shown, the variable resistor 52 on each of the two-dimensional joysticks 44 is influenced by vertical motion. With the appropriate electrical connections 56, each of the variable resistors 52 will output a higher voltage when the central body portion 42 is raised, and a lower voltage when the central body portion is lowered. If this is taken to be the z axis as discussed above, then x and y axis rotation

-12-

is also detected by these four resistors 52. In the case of rotation, about the x axis, one opposing pair 52a will not change while the other pair 52b will have one variable resistor 52b with a higher value and one variable resistor 52b with a lower value, depending on whether the rotation was in the positive or negative direction. When rotation is about the y-axis, the opposing pair of variable resistors 52a will change while the opposing pair 52b remains unchanged. The other four resistors 50 are also wired so that when the central body portion 52 slides along the y axis, the readings from two resistors 50a increase, while the other two resistors 50b are unaffected. The two resistors 50b are influenced by movement along the x axis, while the other two 50a are unaffected. The z axis rotation is detected by all four of the resistors 50a,b. In a preferred embodiment, the wiring scheme will be such that two of the resistors 50 will increase and two will decrease in voltage for positive rotation and vice versa for negative rotation. The resistors 50, 52 may be replaced with other variable impedance devices such as variable capacitors, etc. It will be appreciated that sensors other than variable impedance sensors may be utilized in keeping with the invention.

From these values, relative motion is detected by applying the proper algorithms to interpretation of the eight input values.

It will be appreciated that numerous alternative designs of the present invention, in keeping with the principles of the invention, might be utilized. For example, individual linear sensors disposed about the central body portion 42 might be used as opposed to two-dimensional joystick devices.

In the embodiment shown, the main handle portion 60 is interconnected to the central body portion for facilitating user manipulation of the central body portion.

-13-

It will be appreciated that the handle portion 60 might take on other configurations such as a sphere, etc. As illustrated in Figure 2, the handle might include a push button switch 61 for deactivating the joystick apparatus such that movement of the joystick does not affect the output from the joystick apparatus. For example, deactivation of the joystick apparatus would allow it to return to its neutral position without affecting its output.

As shown in Figure 2, an embodiment of the present invention might include a mechanism for biasing the control handle 60' back to a neutral position once the user releases the handle. In the embodiment shown, coiled springs 62 are so used to bias the control handle back to a neutral position. The central body portion 42' in this embodiment might be supported by a telescoping member 64.

Illustrated in Figures 9 and 10 is an alternate embodiment of the present invention (parts corresponding to those of Figure 1 being indicated by the same reference numerals, only double primed). In this embodiment, the joysticks 44'' are slidably mounted for linear movement on case bearing shafts 70, the shafts 70 being supported by a bracket 71. A mounting bracket 72 is attached to each of the joysticks 44'' and in turn mounted on the shafts 70 by use of suitable ball bushing mounts 74. It will be appreciated that any number of apparatus and methods might be used to slidably mount the joysticks 44''. In this embodiment, the central body portion 42'' is connected to the joysticks 44'' by a universal joint 76. In this embodiment, the handle members 46'' are not telescoping.

The joystick of the present invention has particular application for manipulation and control of three-dimensional computer generated images. Illustrated in Figure 4 is a block diagram of the joystick 20 of the present invention providing user input to a computer system

-14-

70 for controlling movement of computer generated images on  
a display medium 72. The computer system 70 might include  
controls for ignoring movement of the joystick apparatus  
such that joystick input can be selectively activated and  
5 deactivated. The present invention provides a very  
intuitive and interactive user input device for controlling  
computer generated three-dimensional images on a display  
medium. The present invention has numerous other  
applications such as robotics and avionics for controlling  
10 the movement of objects in three-dimensional space. For  
these and other applications, the computer system 70 might  
also include controls for achieving a desired amount of  
lead or lag of the object or image movement relative to the  
joystick. In addition, velocity and/or acceleration of the  
15 object or image might also be controlled in accordance with  
the joystick movement.

It is to be understood that even though numerous  
characteristics and advantages of various embodiments of  
the present invention have been set forth in the foregoing  
20 description, together with details of the structure and  
function of various embodiments of the invention, this  
disclosure is illustrative only and changes may be made in  
detail, especially in matters of shape, size and  
arrangement of parts, within the principles of the present  
25 invention, to the full extent indicated by the broad  
general meaning of the terms in which the appended claims  
are expressed.



-15-

## WHAT IS CLAIMED IS:

1. A joystick apparatus, comprising:
  - (a) central body means supported for translational and rotational movement in any direction within a limited three-dimensional space; and
  - (b) sensor means spaced apart from the central body means for sensing movement of the central body means.
2. An apparatus in accordance with claim 1, wherein the joystick apparatus includes a plurality of the sensor means disposed about and spaced from the central body means for sensing motion of the central body means in the three-dimensional space.
3. An apparatus in accordance with claim 2, wherein the sensor means are slidably mounted, the central body means being interconnected to the sensor means by universal joint means for enabling universal movement of the central body means relative to the sensor means.
4. An apparatus in accordance with claim 2, wherein the sensor means includes at least three, two-dimensional joystick apparatus.
5. An apparatus in accordance with claim 2, wherein the sensor means include rotational motion sensors, at least two of the rotational sensors cooperating to sense translational motion of the central body means.
6. An apparatus in accordance with claim 2, wherein the sensor means include at least three translational motion sensors.
7. An apparatus in accordance with claim 1, including transducer means for converting the sensed

-16-

movement of the central body means into electrical signals representative of the sensed movement.

5 8. An apparatus in accordance with claim 2, wherein the sensor means include at least three two-dimensional force sensors.

9. An apparatus in accordance with claim 2, wherein the sensor means are disposed in a common plane.

10

10. A computer graphics input device used for controlling movement of an image on a computer graphics display terminal, the input device comprising:

15 (a) body means supported for translational and rotational movement in any direction within a limited three-dimensional space; and

(b) transducer means for sensing movement of the body means and converting the sensed movement into output signals for input to the computer graphics display terminal.

20

11. A joystick apparatus, comprising:

25 (a) a central body portion being supported by support means for translational and rotational movement in any direction within a predefined limited three-dimensional space; and

(b) a plurality of sensor means suitably interconnected thereto for sensing translational motion, two or more of the sensor means cooperating to sense rotational motion.

30

12. A joystick apparatus in accordance with claim 11, wherein the sensor means are radially removed from and disposed about the central body portion in a common plane.

35

-17-

13. A joystick apparatus in accordance with claim 12, wherein the sensor means are disposed about the central body portion at substantially one hundred twenty degree intervals.

5

14. A joystick apparatus in accordance with claim 11, wherein the sensor means include a plurality of linear sensors each capable of sensing one-dimensional movement.

10

15. A joystick apparatus in accordance with claim 13, wherein cooperating pairs of the linear sensors form two-dimensional sensor means disposed about the central body portion.

15

16. A joystick apparatus, comprising:

(a) a support base;

(b) a central body portion;

(c) at least three, two-dimensional joystick

apparatus each having a base portion and control handle means interconnected to the base portion so as to have two degrees of motion, the two-dimensional joystick apparatus including sensor means for sensing movement of the control handle means relative to the base portion and for providing output signals representative of such movement, the control handle means of the two-dimensional joystick apparatus being interconnected to the central body portion by universal joint means for universal movement relative to the central body portion, adjustable length means cooperating with the handle means for providing variable displacement between the central body portion and the base portions of the two-dimensional joystick apparatus, whereby the central body portion can be moved in all directions so as to be provided with six degrees of motion, namely, translational motion along the x, y and z axes and rotational motion about the x, y and z axes; and

35

-18-

(d) main control handle means extending from the central body portion for facilitating user manipulation of the central body portion.

5 17. An apparatus in accordance with claim 16, wherein the universal joint means are disposed about the central body portion at predetermined locations.

18. An apparatus in accordance with claim 16, wherein  
10 the universal joint means are disposed about the central body portion in a common plane at ninety degree intervals.

19. An apparatus in accordance with claim 16, wherein the u-joint means comprises ball joint means.  
15

20. An apparatus in accordance with claim 16, wherein the adjustable length means includes a plurality of telescoping members.

20 21. An apparatus in accordance with claim 16, wherein the adjustable length means comprises first and second members slidably interconnected.

22. An apparatus in accordance with claim 16, wherein  
25 the sensor means of the two-dimensional joystick means comprises variable impedance devices.

23. An apparatus in accordance with claim 16, wherein there are four two-dimensional joystick apparatus present.  
30

24. An apparatus in accordance with claim 16, further including means for resiliently biasing the central body portion toward a neutral position.

25. An apparatus in accordance with claim 16, wherein each of the two-dimensional joystick means includes first and second variable impedance means, the first variable impedance means on each of the two-dimensional joystick means being influenced by z axis motion of their respective control handle means, whereby z axis translational motion of the central body portion is detected as well as x and y axis rotational motion of the central body portion, a first opposing pair of the second variable impedance means on the two-dimensional joystick means being influenced by x axis translational movement and a second opposing pair of the second variable impedance means on the two-dimensional joystick means being influenced by y axis translational movement, said second variable impedance means further being influenced by z axis rotational movement, whereby z axis rotational movement of the central body portion as well as x and y axis movement of the central body portion is detected.

20 26. A computer graphics system, comprising:  
(a) a display medium;  
(b) a computer system for generating three-dimensional computer images on the display medium; and  
(c) a joystick apparatus having six degrees of motion, namely, translational motion along x, y and z axes and rotational motion about x, y and z axes, providing input to the computer system for user manipulation and control of the three-dimensional image displayed on the display medium by the computer system.

30 27. A computer graphics system in accordance with claim 26, wherein movement of the joystick apparatus corresponds to movement of the three-dimensional image displayed on the display medium by the computer system.

35

28. A computer graphics system in accordance with claim 27, wherein the joystick apparatus includes linear sensor means for providing the input to the computer system.

5

29. A method for manipulation and orientation of objects whether they be physical objects or images on a display media; the method comprising the steps of:

10 (a) manipulating and orientating control handle means in any direction and orientation desired in three-dimensional space;

(b) sensing movement of the control handle means by use of a plurality of sensor means;

15 (c) outputting signals representative of the movement of the central handle means as sensed by the sensor means; and

(d) manipulating and orientating the object corresponding to the movement of the control handle means.

FIG. 1

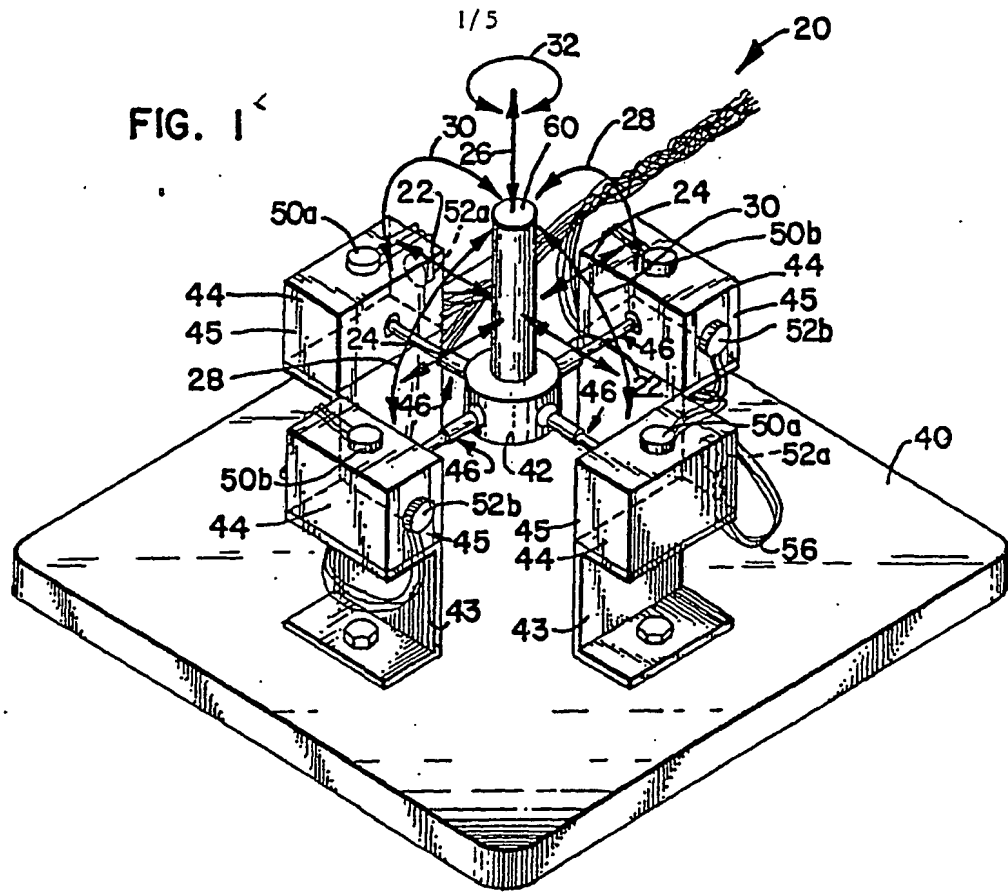

FIG. 4

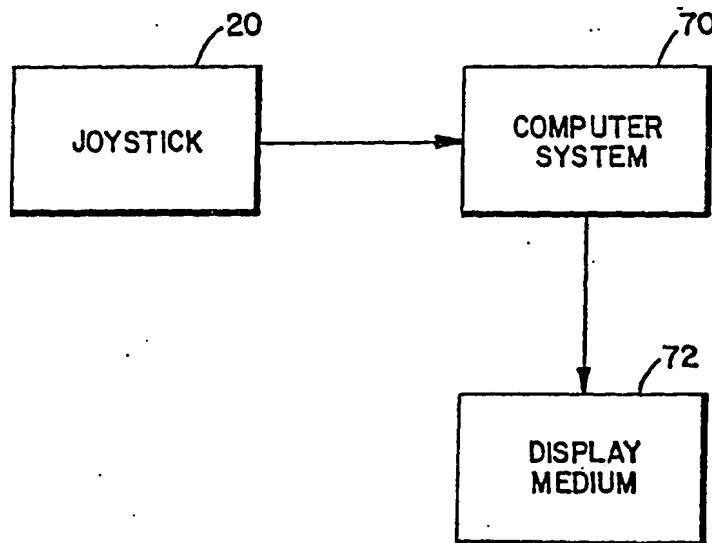

FIG. 2

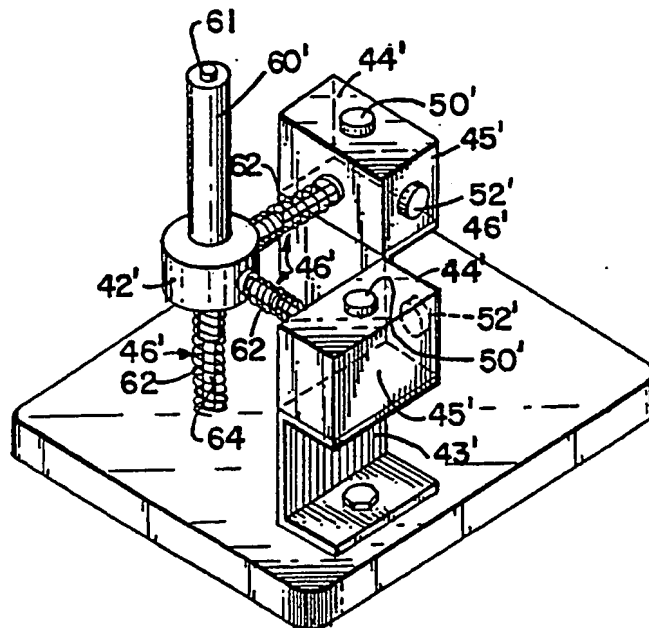

FIG. 3

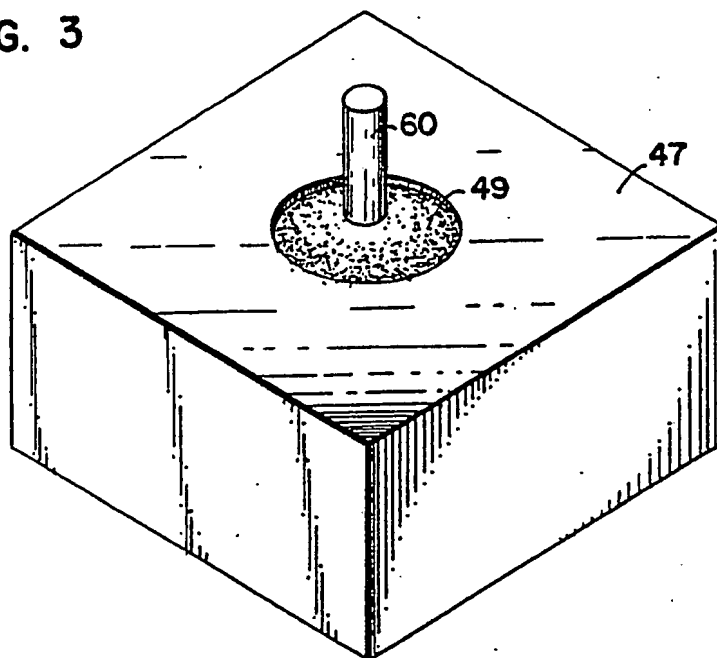



FIG. 5

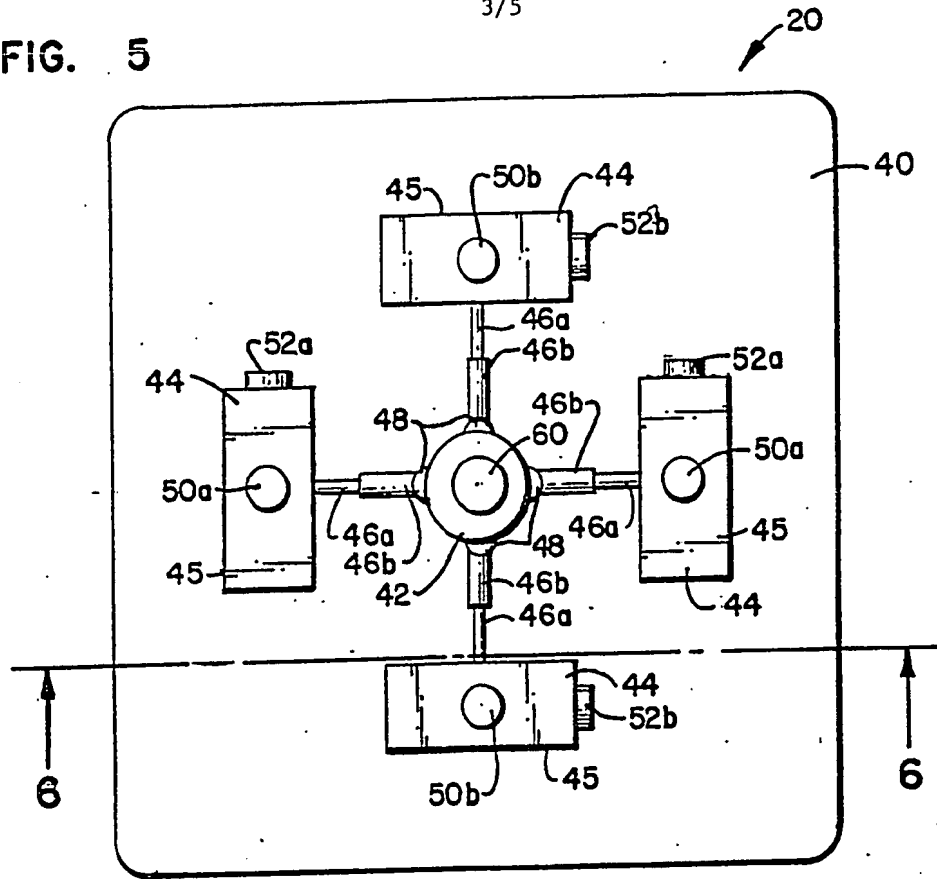

FIG. 6

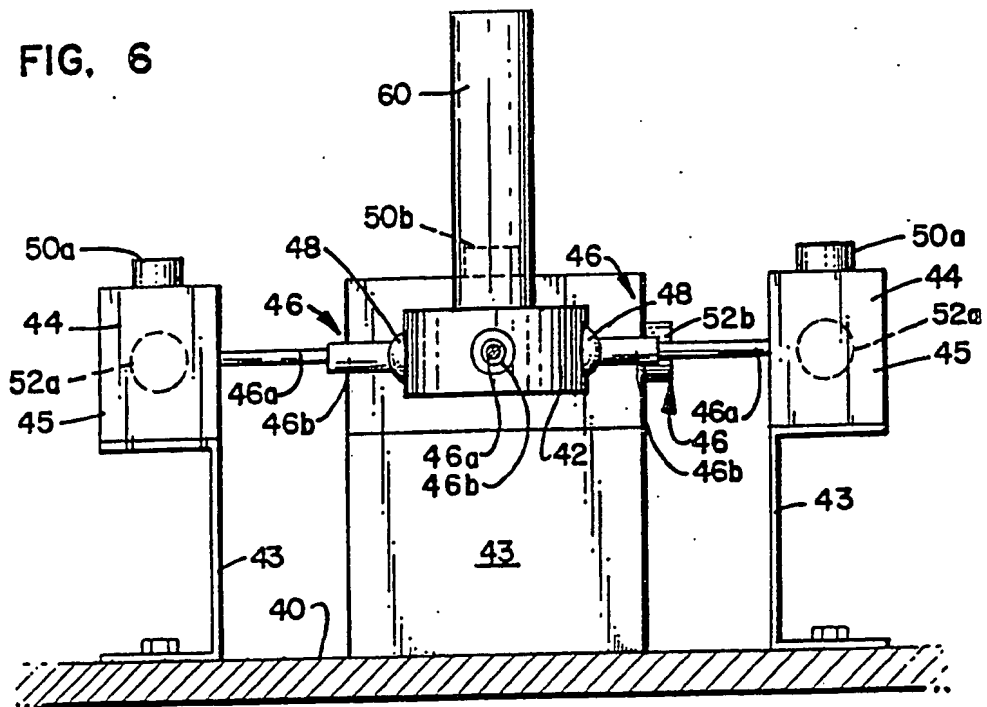

FIG. 7

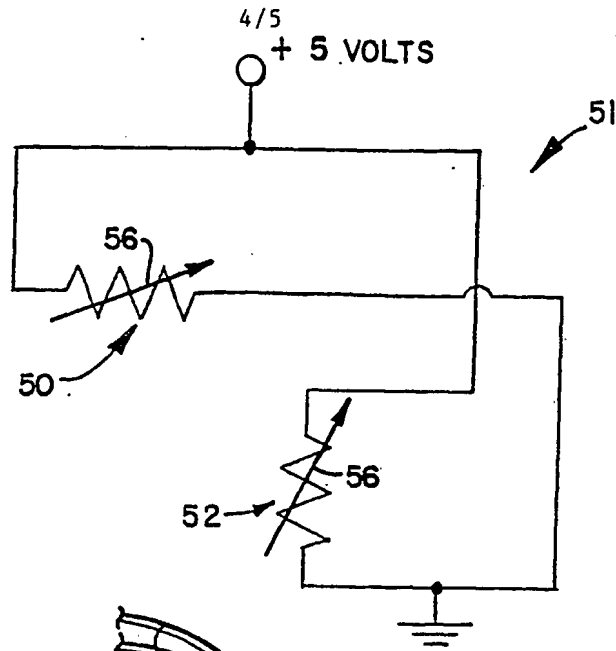

FIG. 8

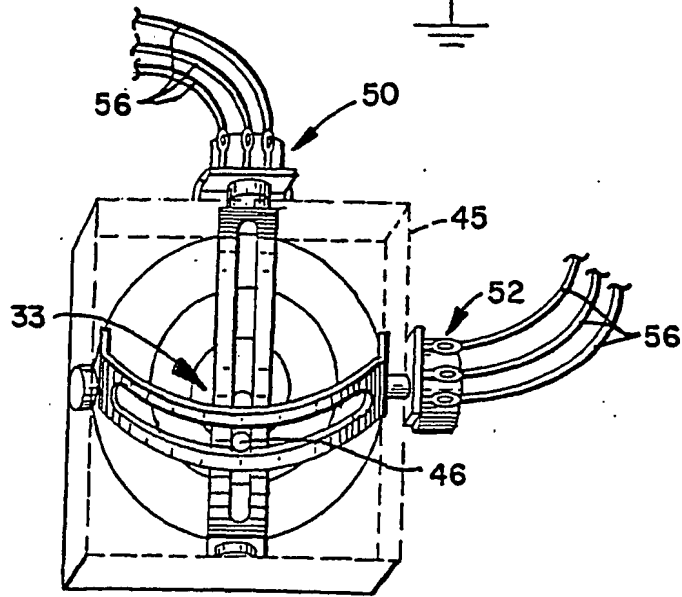

FIG. 9

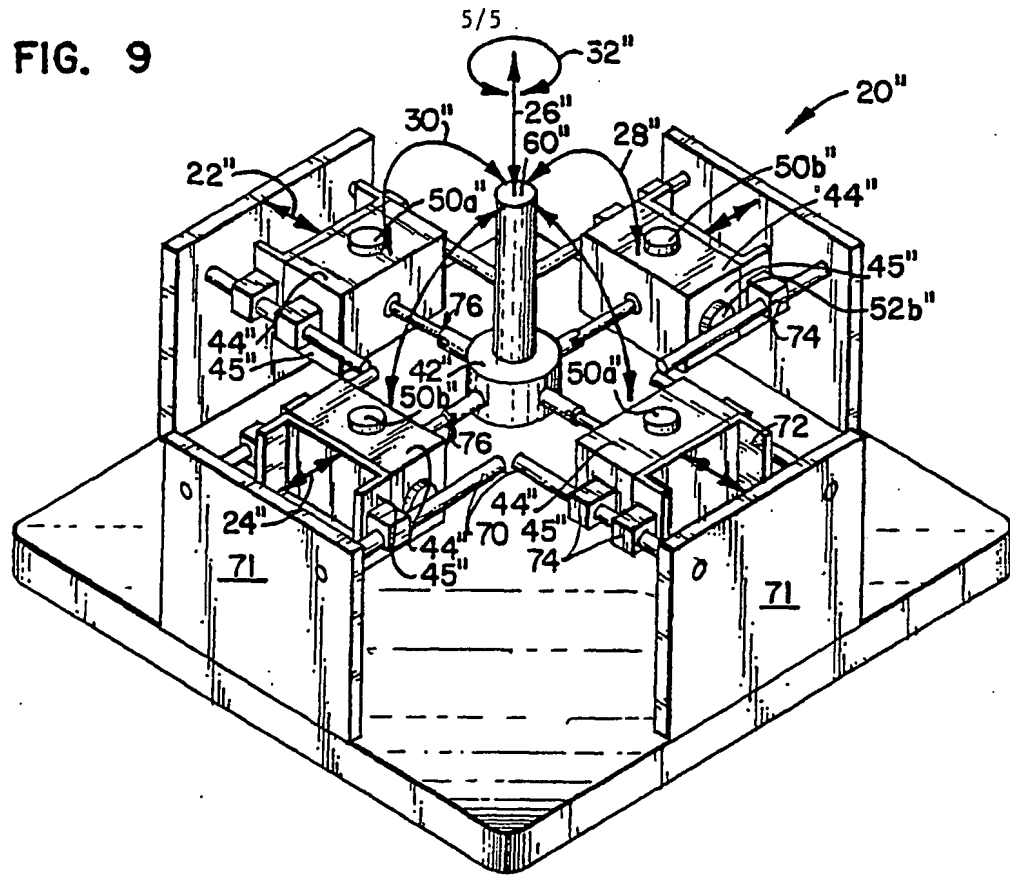
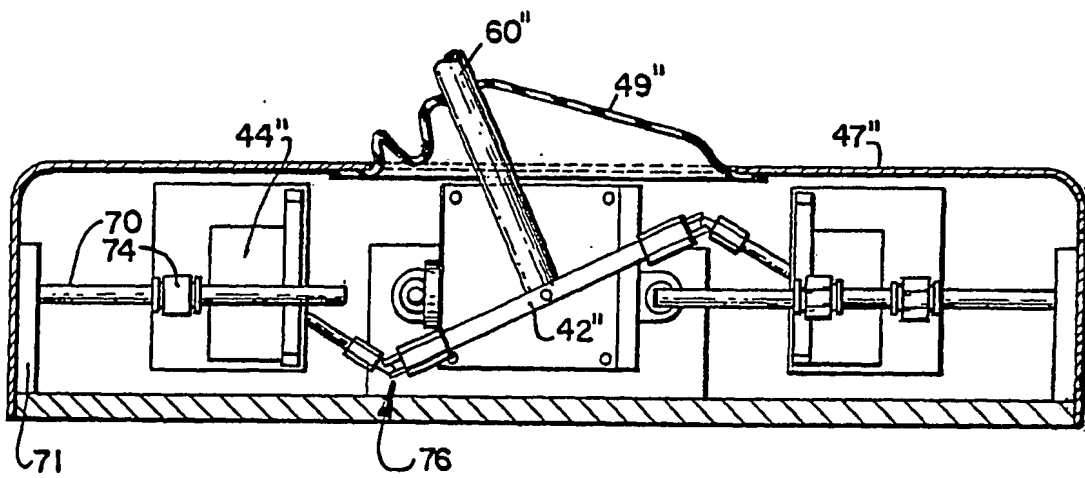

FIG. 10



# INTERNATIONAL SEARCH REPORT

International Application No PCT/US88/00291

<b>I. CLASSIFICATION OF SUBJECT MATTER</b> (if several classification symbols apply, indicate all) *		
According to International Patent Classification (IPC) or to both National Classification and IPC		
IPC (4)	G06F 3/033	
U.S. cl.	340/709	
<b>II. FIELDS SEARCHED</b>		
Minimum Documentation Searched *		
Classification System	Classification Symbols	
U.S.	340/709, 365R, 365S, 365L; 358/22 273/148B; 74/471XY; 250/221	
Documentation Searched other than Minimum Documentation to the Extent that such Documents are Included in the Fields Searched *		
<b>III. DOCUMENTS CONSIDERED TO BE RELEVANT</b> **		
Category *	Citation of Document, <sup>16</sup> with Indication, where appropriate, of the relevant passages <sup>17</sup>	Relevant to Claim No. <sup>18</sup>
Y	U.S. A, 4,468,688 (GABRIEL ET AL) 28 August 1984. See columns 33 and 34.	1-29
Y	U.S. A, 4,161,726 (BURSON ET AL) 17 July 1979. See columns 1 and 2.	3, 16, 17, 18, 19, 20, 21, 22, 23, 24
Y	U.S. A, 3,350,956 (MONGE) 07 November 1967. See the entire document.	1-29
Y	Ciarcia (Joystick Interfaces Publication) BYTE Publication Inc.; Pages 10-18; September 1979; See the entire document.	2, 3, 4, 5, 6, 7, 8, 9, 11, 12, 13, 14, 15, 23, 25
A	Cammichael (Joystick Resolving Mechanism) IBM Technical Disclosure Bulletin; Vol. 21 No. 12 May 1979; Pages 5023-5024.	
A	AHL (Controller Update) Creative Computing December 1983; Pages 142-154.	
<p>* Special categories of cited documents: <sup>15</sup></p> <p>"A" document defining the general state of the art which is not considered to be of particular relevance</p> <p>"E" earlier document but published on or after the international filing date</p> <p>"L" document which may throw doubts on priority claim(s) or which is cited to establish the publication date of another citation; or other special reason (as specified)</p> <p>"O" document referring to an oral disclosure, use, exhibition or other means</p> <p>"P" document published prior to the international filing date but later than the priority date claimed</p> <p>"T" later document published after the international filing date or priority date and not in conflict with the application but cited to understand the principle or theory underlying the invention</p> <p>"X" document of particular relevance: the claimed invention cannot be considered novel or cannot be considered to involve an inventive step</p> <p>"Y" document of particular relevance: the claimed invention cannot be considered to involve an inventive step when the document is combined with one or more other such documents, such combination being obvious to a person skilled in the art.</p> <p>"&amp;" document member of the same patent family</p>		
<b>IV. CERTIFICATION</b>		
Date of the Actual Completion of the International Search *		Date of Mailing of this International Search Report *
26 April 1988		27 MAY 1988
International Searching Authority *		Signature of Authorized Officer <sup>19</sup>
ISA/US		Mahmoud Fatahi-yar

III. DOCUMENTS CONSIDERED TO BE RELEVANT (CONTINUED FROM THE SECOND SHEET)		
Category *	Citation of Document, <sup>16</sup> with indication, where appropriate, of the relevant passages <sup>17</sup>	Relevant to Claim No. <sup>18</sup>
A	U.S. A, 4,216,467 (COLSTON) 05 August 1980.	